

# Soil - Pile - Structure Interaction for Dynamic Design

Chethan B M<sup>a</sup> and Amith kumar<sup>b</sup> Department of Civil Engineering,

OPJS University Near Sankhu Fort, Jhunjhunu Road, Sadulpur, Rajasthan 331303, India.

**ABSTRACT:** *The state of the art on soil-pile-structure interaction is summarized, and focus on the practical applications in seismic design. A boundary zone model developed to account for the nonlinearity of soil approximately, and the curves of stiffness and damping of soil-pile system provided in this study. The radiation damping corrected based on some dynamic tests in the field. The effects of soil-pile-structure interaction on dynamic behaviour examined based on an engineering case with different base conditions, such as the soil-pile-structure interaction accounted for fully, the soil-pile system is flexible but the structure assumed to be rigid, and the structure is flexible but the base foundation assumed to be rigid. For practical applications, a tower structure supported on piled foundation examined under seismic loads. The earthquake forces and response were calculated using the time history analysis and response spectrum analysis, and compared with those using the method of equivalent static loads.*

## 1. Introduction

Great advances have been developed on the subject of soil-pile-structure interaction in the sixty years, and the importance of interaction is recognized widely in the dynamic or seismic design. However, some of the problems still remained and concerned in seismic design. One of the interesting problems is how to account for the nonlinearity of soil in an earthquake environment. The plain strain model of soil-pile system has been improved by a boundary zone model. The curves of stiffness and damping of pile foundations proposed, which vary with the ratio of  $G_i / G_o$  to indicate the nonlinear properties of soil, where  $G_i$  and  $G_o$  is the shear modulus in the boundary zone and the out zone respectively. The radiation damping is also a very important factor to soil-pile-structure interaction and discussed.

The effects of soil-pile-structure interaction are estimated based on an engineering case. The different conditions are considered. In the first case, the soil-pile-structure interaction is accounted for fully, that is, all of the soil, pile and structure are flexible. In the second case, the soil-pile system is flexible, but the structure is assumed to be rigid (no deformation in the superstructure). In the third case, the structure is flexible but fixed (or pinned) to the rigid base, no deformation in base soil (without SSI). As practical applications, a vacuum tower structure is examined in severe seismic zone as a typical industrial structure supported on pile foundation. The vacuum tower sets on a steel frame with height of 20 m. There are 25 steel piles in the foundation. Three different base conditions are assumed to illustrate the soil-pile-structure interaction: rigid base, i.e. no deformation in the foundation, linear soil-pile system; and nonlinear soil-pile system. The case of liquefaction of sand layer is discussed for the pile foundation. The seismic response are calculated from the response spectrum analysis and time history analysis considering the soil-pile-structure interaction, and compared with the method of equivalent static loads.

## 2. Nonlinear Soil - Pile System

Many researchers have made contributions to the subject of soil-pile-structure interaction. Different approaches are available to account for dynamic soil-pile interaction but they are usually based on the assumptions that the soil behavior governed by the law of linear elasticity or visco-elasticity, and that the soil is perfectly bonded to a pile. In practice, however, the bonding between the soil and the pile is rarely perfect, and slippage or even separation often occurs in the contact area. Furthermore, the soil region immediately adjacent to the pile can undergo a large degree of straining, which would cause the soil-pile system to behave in a nonlinear manner. Many efforts made to model the soil-pile interaction using the 3D Finite Element Method (FEM). However, it is too complex, especially for pile groups in nonlinear soil. A rigorous approach to the nonlinearity of a soil-pile system is extremely difficult and time consuming.

As an approximate analysis, a procedure developed using a combination of the analytical solution and the numerical solution, rather than using the general FEM. This procedure considered as an efficient technique for solving the nonlinear soil-pile system. The relationship between the foundation vibration and the resistance of the side soil layers was derived using elastic theory by Baranov (1967). Both theoretical and experimental studies have shown that the dynamic response of piles is very sensitive to the properties of the soil in the vicinity of the pile shaft seeing Han and Novak (1988). Velestos and Dotson (1988) proposed a scheme that can account for the mass of the boundary zone. Some of the effects of the boundary zone mass were investigated by Novak and Han (1990), who found that a homogeneous boundary zone with a non-zero mass yields undulation impedance due to wave reflections from the fictitious interface between the two media.

The ideal model for the boundary zone should have properties smoothly approaching those of the outer zone to alleviate wave reflections from the interface. Consequently, Han and Sabin (1995) proposed a model for the boundary zone with a non-reflective interface. The complex shear modulus,  $G(r)$ , varies parabolically. The modulus ratio  $G_i / G_o$  is an approximate indicator for the nonlinear behavior of soil. The value of the modulus ratio depends on the method for pile installation, the density of excitation and vibration amplitudes. Further dynamic tests on piles needed to determine the value of the modulus ratio. The model of the boundary zone with a non-reflective interface has applied to practice to solve approximately the problem of nonlinear soil. However, it should explain that the method described here is not a rigorous approach to modeling the nonlinearity of a soil-pile system. It is an equivalent linear method with a lower value of  $G_i$  and a higher value of damping  $\zeta_i$  in the boundary zone. With such a model, the analytical solutions can obtain for the impedance functions of a pile. The group effect of piles is accounted for using the method of interaction factors. The static interaction factors can use based on Poulos and Davis (1980). The dynamic interaction factors derived from the static interaction factors multiplied by a frequency variation, and the frequency variation of interaction factors based on the charts of Kaynia and Kausel (1982).

There are six degrees of freedom for the rigid mat, and lateral vibration coupled to rocking vibration. It should explain that the foundations (or caps on piles) assumed as rigid. However, in most cases, the superstructures are flexible rather than rigid. The effects of soil-pile-structure interaction on dynamic response discussed, and the dynamic response of the superstructure can be calculated using FEM models.

For the pile foundation under static loads, the differential equation for a beam-column can be solved using nonlinear lateral load-transfer ( $p$ - $y$ ) curves. Nonlinear lateral load-transfer from the foundation to the soil is modeled using  $p$ - $y$  curves generated by computer program LPILE for various types of soil. Unfortunately, the dynamic equations of soil-pile system can be not solved analytically by using the  $p$ - $y$  curves. An approximate analysis has to be used for the dynamic analysis of pile foundations. The dynamic equations have been solved using the ratio of shear modulus  $G_i / G_o$  to indicate the nonlinear properties of soil. The plane-strain model is improved by the boundary zone model for the soil-pile system. The nonlinear variation curves of stiffness and damping and range of values for  $G_i / G_o$  are described in the following. The normalized stiffness and damping of pile foundation varied with  $G_i / G_o$  as shown in Figure 1 and Figure 2 respectively. The values of stiffness and damping are generated using the program DYNAN, and applicable to general pile foundations including concrete piles and steel piles. The stiffness and damping are frequency dependent. The values of stiffness and damping are normalized to show the effects of  $G_i / G_o$ . The normalized stiffness and damping are defined as the dynamic stiffness and damping to be divided by static values. It should be explained that the static stiffness can be not generated directly from the program, and the values of stiffness and damping in very low frequency domain such as 0.01 Hz were assumed to be close to as static values.

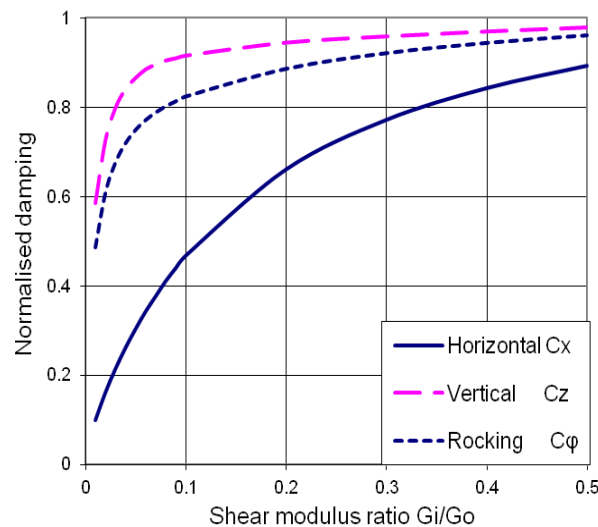
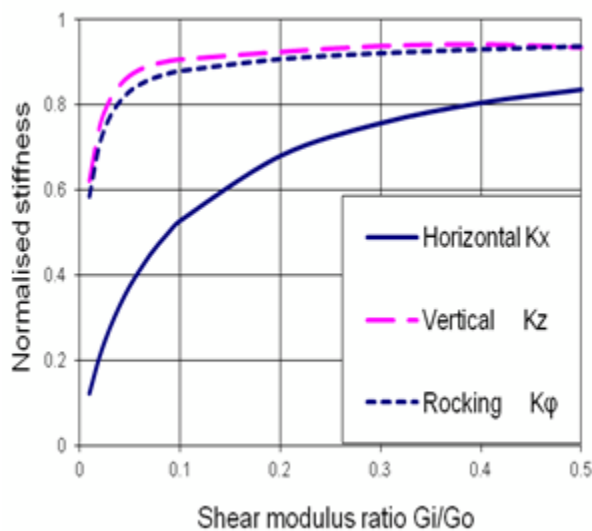

**Fig. 1. Normalized stiffness of piles vs  $G_i / G_o$       Fig. 2. Normalized damping of piles vs  $G_i / G_o$**

From Figures 1 and 2, it can be seen that the variation of stiffness and damping is larger for horizontal vibration than those for vertical and rocking vibration. It is concluded that the effects of  $G_i / G_o$  are more significant on lateral impedances than those on vertical and rocking impedances. Also, it is noted that the stiffness and damping vary gently as  $G_i / G_o = 0.25 - 0.5$ , and vary sharply as  $G_i / G_o < 0.25$ . As  $G_i / G_o < 0.1$ , the stiffness and damping are reduced seriously for all of the vibration modes, such as under seismic loads. It can be seen that the vibration intensity of pile vary with the value of  $G_i / G_o$ , and the reduction increases with the vibration intensity. Based on dynamic tests of pile foundations, it is suggested that  $G_i / G_o = 0.25 - 0.5$  for design of machine foundations, and the value may be  $G_i / G_o < 0.25$  for strong earthquake response. Based on the relation between the shear wave velocity  $V_s$  and the modulus  $G$ , it can be converted  $V_s$  in the boundary zone. Such as  $V_s$  is reduced to about 50%

to 70%, corresponding to  $G_i / G_o = 0.25 - 0.5$ .  $V_s$  is reduced to less than 50% corresponding to  $G_i / G_o < 0.25$ , and  $V_s$  is reduced to about 1/3 corresponding to  $G_i / G_o = 0.1$ .

The radiation damping is also a very important factor for the soil-pile-structure interaction. The elastic-wave energy from foundation vibration dissipated in three dimensions to form the radiation damping. The radiation damping is the dominant energy dissipation mechanism in most dynamically loaded foundation systems. The formula of radiation damping derived based on elastic theory in which the soil assumed to a homogeneous isotropic medium. However, the soil is not a perfect linear elastic medium as assumed. A series of dynamic experiments have been done and indicated that the damping to be overestimated in the elastic theory seeing Han (2008). The values of radiation damping modified and reduced in DYNAN program based on the measurements in practice.

### 3. Effects of Soil - Pile - Structure Interaction

Classical empirical methods of dynamic analysis assume that the foundation acts as a rigid body, such as Barkan model (1962). In this study three conditions of soil-pile-structure system were considered. The first case, the soil-pile-structure interaction accounted for fully, all of the soil, pile and structure are flexible. The second case, the soil-pile system is flexible, but the table top structure is assumed to be rigid (no deformation in the superstructure). Normally the dynamic analysis for foundations supporting vibrating equipment conducted in this way. The third case, the columns of table top structure are flexible but fixed (or pinned) to the rigid base, no deformation in base soil (without SSI). In the early year the seismic analysis was generally conducted in this way.

A practical case of a table top structure with a reciprocating compressor foundation is examined to illustrate the effects of soil-pile-structure interaction as shown in Fig.3. There are 47 concrete piles to support the reciprocating compressor foundation, and pile diameter is 0.6 m with length of 49 m. The dimension of mat foundation (pile cap) is 16.6 m by 14.35 m, with thickness of 1.5 m.

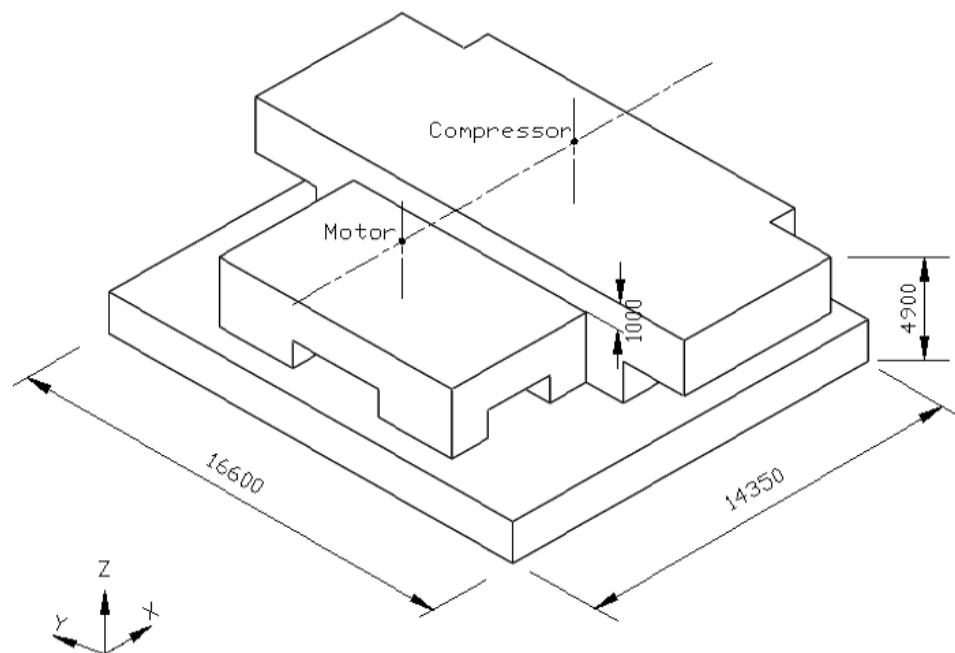

### Fig. 3 Foundation of reciprocating compressor

The stiffness and damping of piles generated by the program as shown in Table 1. The shear modulus ratio  $G_i / G_o = 0.5$  was assumed to indicate the non-linear behavior of soil.

**Table 1 Stiffness and Damping of Pile Foundation**

Stiffness			Damping		
$K_x$ (kN/m)	$K_z$ (kN/m)	$K_\phi$ (kN.m/rad)	$C_x$ (kN/m/s)	$C_z$ (kN/m/s)	$C_\phi$ (kN.m/rad/s)
$2.226 \times 10^6$	$3.227 \times 10^6$	$4.586 \times 10^8$	$1.125 \times 10^5$	$2.667 \times 10^5$	$7.073 \times 10^6$

Where  $K_x$ ,  $K_z$ , and  $K_\phi$  are stiffness in the horizontal, vertical and rocking directions, and  $C_x$ ,  $C_z$ , and  $C_\phi$  are damping constants in the same directions.

The dynamic response of table top structure was analyzed by using the finite element model from SAP 2000 with the input of foundation parameter stiffness and damping as listed in Table 1. The displacement curves calculated at the corners of deck slab as shown in Fig. 4. It should be explained that the response of foundation is a coupled vibration between three translational and three rotational modes, although only horizontal and vertical behavior are described herein. It can be seen that the peak value of amplitude is  $A_x = 426 \mu\text{m}$  at frequency 5.0 Hz. Amplitude  $A_x = 47 \mu\text{m}$  at operating speed of 6.67 Hz (400 rpm).

For the second case, the deformation of base soil is accounted, but the table top structure is assumed to be rigid. The stiffness and damping of piles are generated as the same as in the first case. The same loads are applied to the structure. The displacement curves calculated at the same points as shown in Fig. 5. It can be seen that the peak value of amplitude is  $A_x = 50 \mu\text{m}$  at frequency 4 Hz. Amplitude  $A_x = 25 \mu\text{m}$  at operating speed. The deformation of superstructure is not considered since it is assumed as rigid. It can be seen that the resonant frequency is close to that or a little lower than that in Fig. 4, but the dynamic response is underestimated significantly.

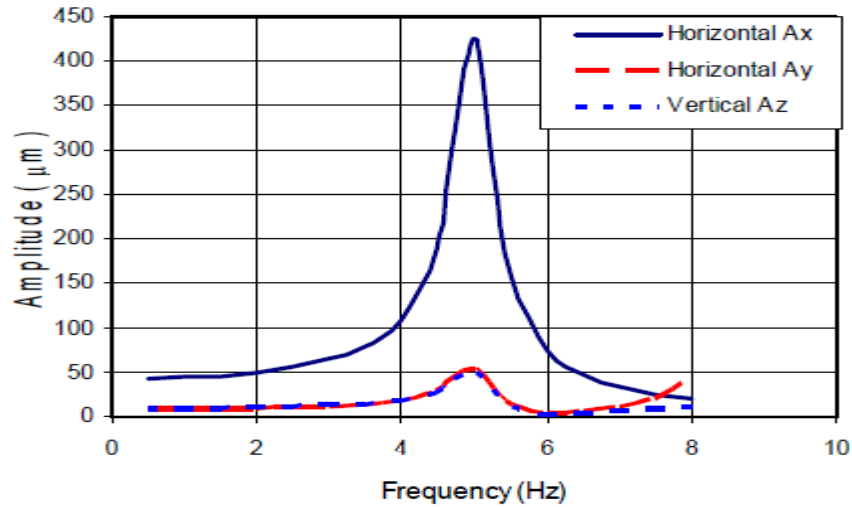

**Fig. 4 Dynamic Response of Structure with Soil-Pile-Structure Interaction**

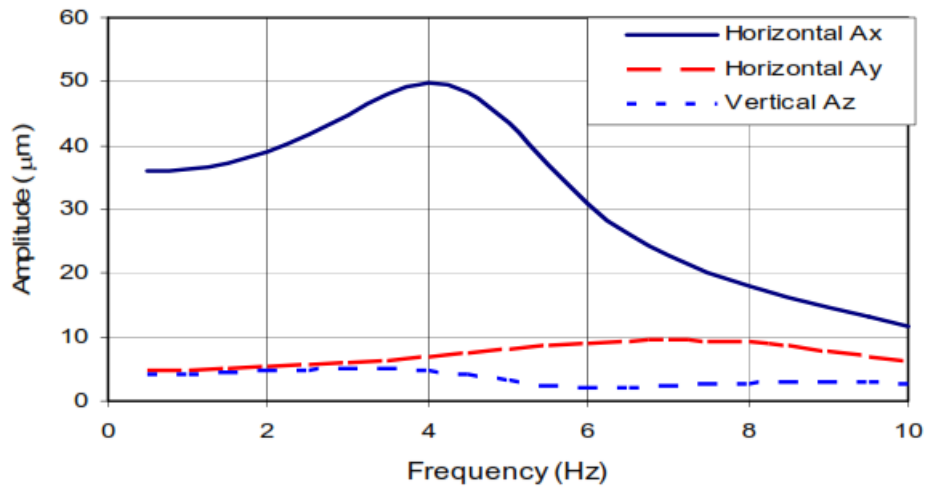

**Fig.5. Rigid Structure Rest on Flexible Piles**

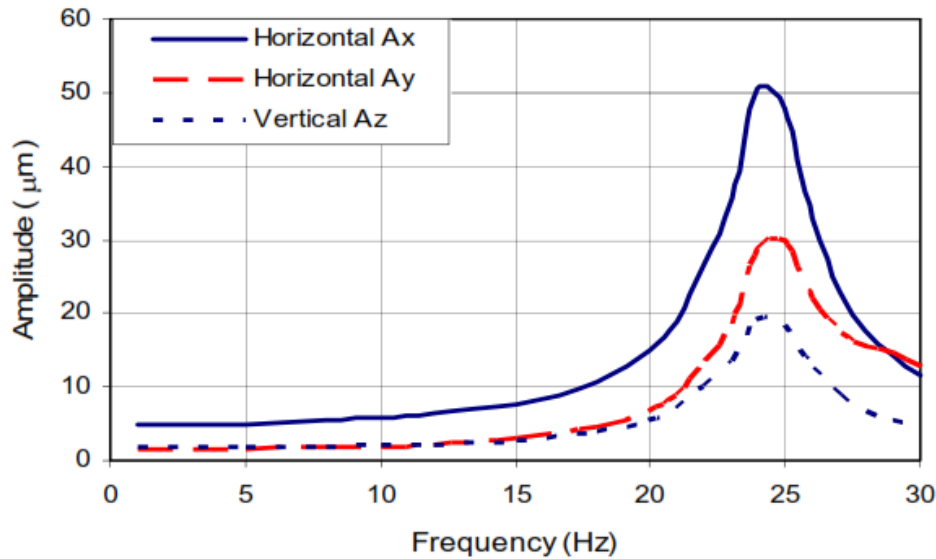

**Fig.6. Flexible Structure Rest on Rigid Base (without SSI)**

For the third case, the columns of table top structure were pinned to the rigid base (no SSI). The superstructure is flexible but the deformation of base soil ignored. The structure subjected to the same loads, and modeled by the same FEM model. The displacement curves calculated at the same points as shown in Fig. 6. It can be seen that the peak value of amplitude is  $A_x = 51 \mu\text{m}$  at frequency 24 Hz. Amplitude  $A_x = 5.0 \mu\text{m}$  at operating speed. In this case, the resonant frequency is very high since the soil-structure interaction ignored. The vibration produced only in the superstructure, and no deformation is considered in the soil-foundation portion. Obviously, it is not true in real situations. The stiffness of structure was overestimated since it was fixed to the rigid base. The damping was underestimated since the energy of vibration transferred through soil (radiation damping) was ignored.

From the above comparison it can be seen that the dynamic response of structure with varied conditions is quite different. Not only the amplitudes varied at operating speed, but also the resonant frequencies and peak values are very different. As shown in Fig. 4, the peak value is much higher and strong vibration is predicted in the resonant frequency domain. The vibration occurred in the entire superstructure (table top structure) and the soil-foundation portion. It is interesting to note that the values of amplitude calculated with the soil-pile-structure interaction (Fig. 4) are close to that calculated with the rigid superstructure and the flexible soil-pile system (Fig. 5) in a very lower frequency range, such as 0.5 to 2 Hz. However, the difference between the two curves becomes large with frequency increasing. The higher values of amplitudes in Fig. 4 come from some higher modes at some locations of the superstructure.

With the comparisons above, the role of soil, piles and structure in the dynamic response can be identified. The range of material damping ratio for concrete structures is 0.02 to 0.05. The damping ratio was taken as 0.02 for all of the three cases. A higher damping is involved with soil-pile interaction, and the damping comes mainly from the radiation damping of soil.

#### 4. Seismic Response of Vacuum Tower

A vacuum tower structure was constructed as shown in Fig. 7 in a seismically active area. At the site, surface soil is soft clay with a depth of 2 m, underlain by a layer of saturate fine sand with a depth of 2 m, followed by some silty clay and dense sand layers with depths of 4 to 8 m in each layer, then bedrock. The depth to bedrock is about 30 m. Soil properties vary with depth and are characterized by the shear wave velocity and unit weight, as shown in Table 2. The ground water is close to the surface.

It is interesting to note that the top layer of fine sand with depth of 2 - 4 m. The fine sand layer is saturated below underground water. Assumed the potential liquefaction occurs in the sand layer, and the surface layer of soft clay doesn't be destroyed yet. The stiffness and damping with liquefaction is considered in this study. The shear wave velocity is zero in depth of 2 - 4 m, and still 130 m/s in depth of 0 - 2 m.

**Table 2. Soil Properties**

Depth (m)	Soil	Unit Weight (kN/m <sup>3</sup> )	Shear Wave Velocity (m/s)
0 - 2	Soft Clay	18	130
2 - 4	Fine Sand	18	140
4 - 12	Stiff Clay	20	300
12 - 16	Silty Sand	19	240
16 - 20	Silty Clay	18	300
20 - 25	Weathered Shale	18	200
25 - 30	Dense Sand	20	300
Below 30	Bedrock	21.5	370



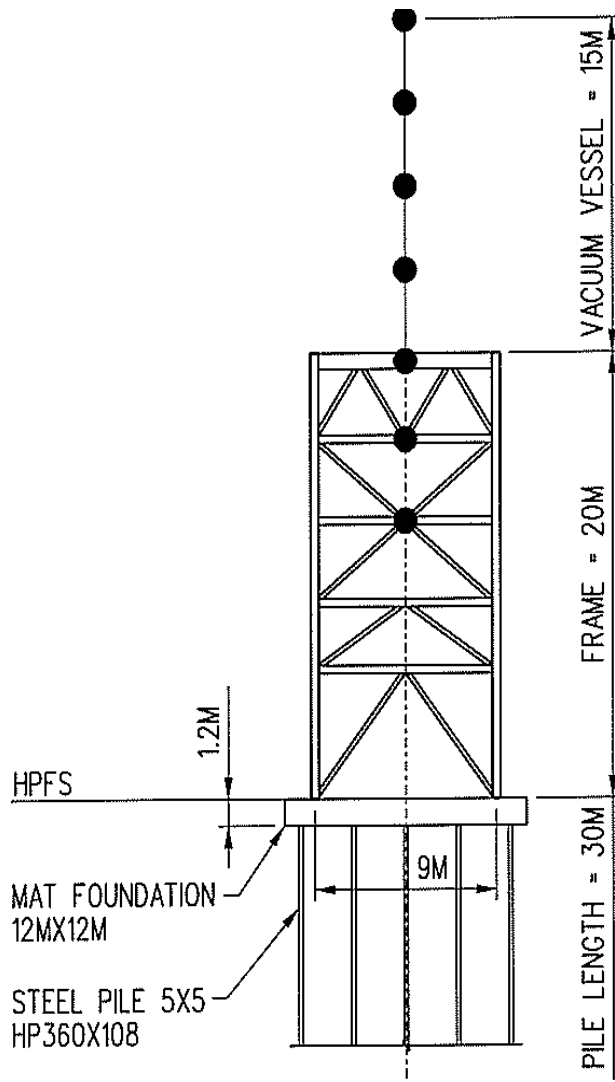

Fig. 7 Vacuum tower structure

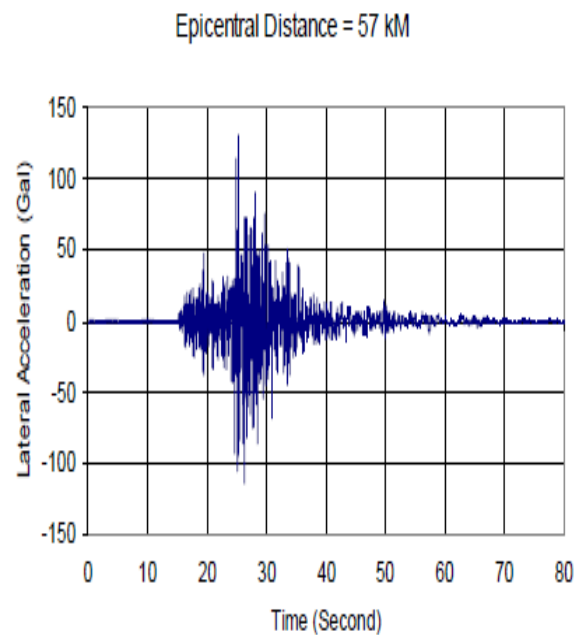

Fig. 8 Horizontal ground acceleration from an earthquake record

The concrete mat foundation is 12 x 12 m with a thickness of 1.2 m. The piles are steel HP 360 x 108 with length of 30 m driven to bedrock. Twenty-five piles in a square pattern were fixed to the mat foundation. The vacuum vessel is modelled as an elastic column with the mass distributed uniformly along its height, and the thickness of vessel wall is 25.4 mm (one inch). The steel structure is modelled using frame elements and the mat foundation is modelled using shell elements. The seismic response of the structure is calculated using FEM model by SAP 2000 program. The deflection of structure, base shear and overturning moments are investigated for different base conditions.

Time history analysis is carried out with the soil-pile-structure interaction. A record of horizontal ground acceleration from an earthquake was employed for the time history analysis. The peak value of acceleration is 0.13 g as shown in Fig. 8. The time step is 0.005 second, and duration is 80 second in the earthquake record.

The stiffness and damping of the pile foundation were calculated for different base conditions. In the first case a linear soil-pile system is assumed, that is, the soil layers are homogeneous, without the weakened zone.

**Table 3. Stiffness and Damping of Pile Foundation**

Soil status	Stiffness			Damping		
	$K_x$ (kN/m)	$K_z$ (kN/m)	$K_\phi$ (kN.m/ra)	$C_x$ (kN/m/s)	$C_z$ (kN/m/s)	$C_\phi$ (kN.m/rad/s)
Linear	$1.283 \times 10^6$	$3.215 \times 10^6$	$1.333 \times 10^8$	$1.244 \times 10^4$	$1.803 \times 10^4$	$6.411 \times 10^5$
Nonlinear	$0.646 \times 10^6$	$2.877 \times 10^6$	$1.160 \times 10^8$	$0.998 \times 10^4$	$1.005 \times 10^4$	$3.171 \times 10^5$
Liquefaction	$0.180 \times 10^6$	$2.527 \times 10^6$	$1.006 \times 10^8$	$0.749 \times 10^4$	$0.943 \times 10^4$	$2.787 \times 10^5$

In the second case, a nonlinear soil-pile system is assumed, and the boundary zone is considered around the piles. The parameters of the boundary zone were selected as:  $G_i / G_o = 0.25$ . In the third case, liquefaction was assumed in the saturated fine sand layer (stiffness of this layer is zero), and the top layer of soft clay assumed not be destroyed. Both stiffness and damping are frequency dependent. Since the fundamental period of the structure is closed to 1.0 second, the stiffness and damping were calculated at a frequency of 1.0 Hz. The stiffness and damping calculated are shown in Table 3. Where,  $K_x$ ,  $K_z$ , and  $K_\phi$  are stiffness in the horizontal, vertical and rocking directions, and  $C_x$ ,  $C_z$ , and  $C_\phi$  are damping constants in the same directions. It is interesting to see that both stiffness and damping are lower in the nonlinear case than those in the linear case, such as the horizontal stiffness  $K_x$  reduced to half by the nonlinear soil. Even more reduction made by the liquefaction of fine sand layer in depth 2 – 4 m, such as the reduction of more than 80% made for horizontal stiffness  $K_x$ .

To investigate the influence of foundation flexibility on the superstructure, the seismic analysis of the structure was conducted for three different base conditions: rigid base, linear and nonlinear soil-pile systems. The seismic response and forces of the structure were analyzed using a FEM model. The vacuum vessel was modelled as an elastic column with the mass distributed uniformly along its height. The steel structure was modelled using frame elements and the mat foundation was modelled using shell elements. The stiffness and damping of the pile foundation were generated for the three base conditions. The deflection, base shear and overturning moment are shown in Table 4.

**Table 4. Seismic Response and Seismic Forces of Tower Structure**

Base Conditions	Amplitude at Tower (mm)	Base Shear (kN)	Overturn Moment (kN-m)
Fixed Base	22.05	807	19,630
Linear Soil	26.30	598	14,980
Nonlinear Soil	26.05	545	14,120

**Table 5. Comparison of Seismic Forces and Response by Different Analysis**

Method of analysis	Amplitude at Tower (mm)	Base Shear (kN)	Overturning Moment (kN-m)
Time history	22.05	807	19,630
Response spectrum	24.1	897	21,349
Equivalent static forces	20.9	862	20,516

From Table 4, it can be seen that the earthquake forces for the fixed base condition are larger than those for the cases with the soil-structure interaction. The theoretical prediction does not represent the real seismic response, since the stiffness is overestimated and the damping is underestimated for a structure fixed on a rigid base. From the comparison, it can be seen that the maximum values and time histories for the seismic forces and seismic response are different when the foundation is considered as a fixed base or a flexible base.

The seismic response and seismic forces were calculated, and the comparison of results from the time history analysis, the response spectrum analysis and the method of equivalent static forces are shown in Table 5. It can be seen that the results calculated from different methods are conformable.

## 5. Conclusions

The software is available considering soil-pile-structure interaction to applications in practice. The engineering cases examined, and the following conclusions made.

The soil-pile interaction is an important factor which affects to the stiffness and damping of the foundation, and also to the dynamic behaviour of structure.

The dynamic response of complex structures can be calculated considering the soil-pile-structure interaction fully. If a rigid base is assumed, the damping would be underestimated and the stiffness would be overestimated. If the superstructure is assumed as rigid, the dynamic response would be underestimated significantly in some cases, since the contribution from high modes of structure is ignored.

The predicted seismic response and earthquake forces are conformable for three different analytical methods, including the time history analysis, response spectrum analysis and equivalent static forces.

## 6. References

1. Banerjee, P.K. and Sen, R. "Dynamic behavior of axially and laterally loaded piles and pile groups". Chapter 3 in *Dynamic Behavior of Foundations and Buried Structures*, Elsevier App. Sc., London, 1987, 95-133.
2. Baranov, V.A., "On the calculation of excited vibrations of an embedded foundation". *Voprosy Dynamiki Prochnosti*, No.14, 195-209, 1967. (in Russian).
3. Barkan, D.D. "Dynamics of bases and foundations". McGraw-Hill Book Co., 1962. New York.
4. Dobry, R. and Gazetas, G. "Simple method for dynamic stiffness and damping of floating pile groups". *Geotechnique*, Vol.38, No.4, 1988. 557- 574.
5. El-Marsafawi, H., Han, Y.C. and Novak, M.. "Dynamic experiments on two pile groups".
6. *J. Geotech. Eng., ASCE*, 118 (4), 1992, 576-592.
7. Gazetas, G. and Makris, N. "Dynamic pile-soil-pile interaction". I: Analysis of Axial Vibration. *J. Earthq. Eng. and Struct. Dyn.* Vol. 20, No.2, 1991.
8. Han, Y.C. "Study of vibrating foundation considering soil-pile-structure interaction for practical applications". *J. of Earthquake Engineering and Engineering Vibration*, Vol.7, No.3, 2008, 321-327.

9. Han, Y.C. and Sabin, G. "Impedances for radially inhomogeneous soil media with a non-reflective boundary". J. of Engineering Mechanics, ASCE, 121(9), 1995, 939-947.
10. Han, Y.C. "Coupled vibration of embedded foundation". J. Geotech. Eng., ASCE, 115 (9), 1989, 1227-1238.
11. Han, Y.C. and Novak, M. "Dynamic behavior of single piles under strong harmonic excitation". Canadian Geotechnical Journal, 25(3), 1988, 523-534.

